

ZHT

Group s.r.o.

ZABRANSKY HIGH TECHNOLOGY



**HIGHEST PERFORMANCE
IN ITS CLASS**

**Performance 1180 LPM
& 4,5 bar officially certified**

Amphibio Hydra 2

NEW FLOATING PUMP



New floating pump Hydra 2 with a superb new design and the highest performance in its category.

Perfect solution for pumping water from natural sources and filling up water tenders.

Efficient helper for firefighters and wherever a rapid intervention is required (municipal services, forests, buildings or construction companies).

USE FOR:

- Filling up water tenders
- Drainage of flooded areas
- Extinguishing fires

Helping those who help others

www.zht.cz

AMPHIBIO HYDRA 2 PERFORMANCE CURVE

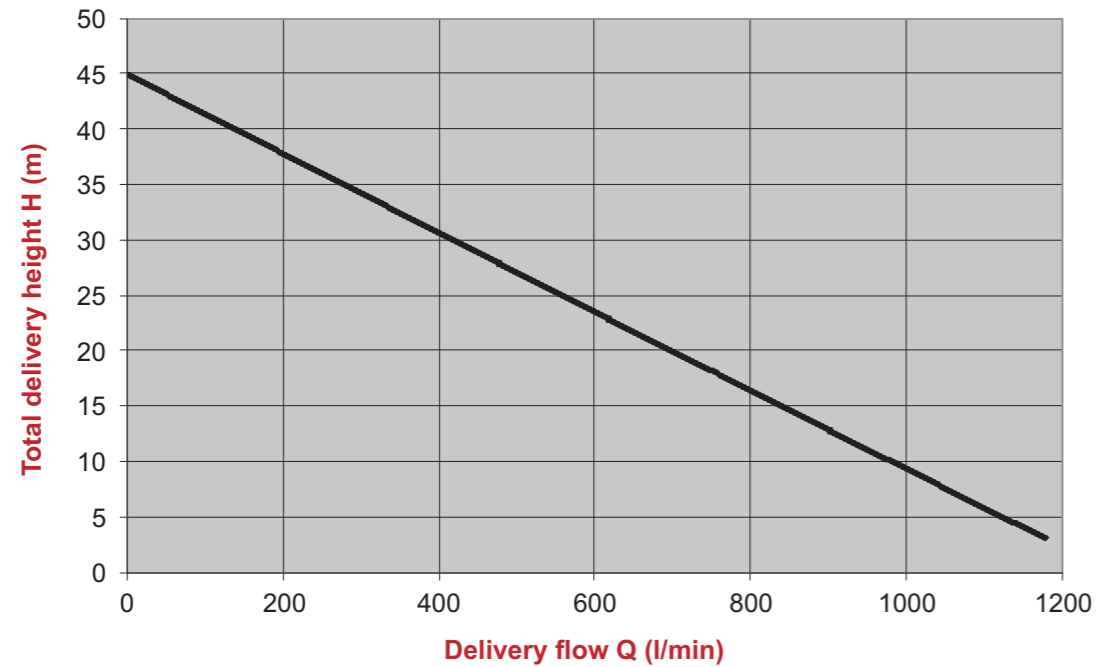

NEW CONSTRUCTION FOR HIGH PERFORMANCE

Due to the perfectly tuned combination of pressure and flow rate Amphibio Hydra 2 provides such high performance that it allows for the pump to be used for extinguishing fires. Amphibio Hydra 2 provides the highest performance among all pumps in its category.

INTEGRATED FUEL TANK

The pump is now fitted with a larger fuel tank with volume of 6 L which allows the pump to run for more than 3 hours of continuous operation.

NEW ERGONOMIC DESIGN

The new superb design allows for better ergonomics of the float and introduces four handles for easier manipulation. The shape and compact dimensions of the float enable better stowage and higher stability on water surface.



ZABRANSKY HIGH TECHNOLOGY

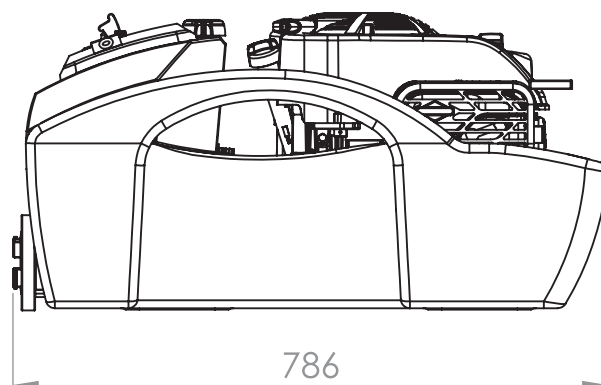
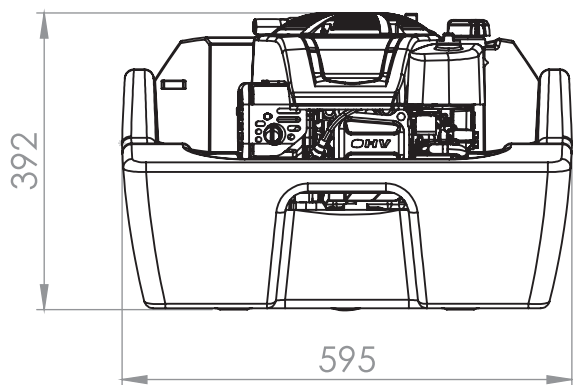

PARAMETERS

Nominal max. output	1180 LPM
Nominal max. pressure	4,5 bar
Pumping head	Up to 45 m of water column
Outlet diameter	65 mm / B75
Min. suction depth	15 mm
Engine	Briggs and Stratton
Starting system	Manual
Tank capacity	6 L
Operation time at full fuel tank	More than 3 hours
Weight	Dry 27 kg/ Operation 32 kg
Dimensions	786 x 595 x 392 mm

Performance of Amphibio Hydra 2 officially certified

